

What's New / 2

What's Important / 3

Model Lineup / 4 - 5

Purchase Motivators	Reference
Performance/Handling / 6 - 10	Audio / 16
Comfort/Convenience / 11 - 12	Wheels/Seats / 17
Design/Styling / 13	Instrument Cluster/Weights / 18
Safety/Security / 14	Dimensions and Specifications / 19 - 24
Quality/Reliability/Durability / 15	Accessories / 25 - 26

Accessories / 25, 26

Audio / 11, 12, 16

Premium AM/FM Stereo/6-disc In-dash CD Player

Hybrid Energy/Navigation/Audio System

SIRIUS Satellite Radio

Battery Recycling Program / 8

Battery Safety / 8, 14

Battery Saver / 14

Battery State Gauge / 8, 11

Belt-Minder® System / 14

Body Structure / 13

Bumpers / 13

Cargo Area / 12

Center Rear Head Restraint / 11

Climate Controls / 10

Colors, Interior and Exterior / 13

Driving Experience / 9

Starting the Vehicle

Driving the Vehicle

Unique Operating Characteristics

Electric Generator Motor / 6, 7

Electronically Controlled Continuously Variable Transmission (eCVT) / 6, 7, 9

Electronic Brake Force Distribution / 14

Emissions / 10

Exterior Design / 13

5-passenger Seating / 11

Flip-up Rear Glass Liftgate / 13

Flow-through Floor Console / 11

Four-wheel Anti-lock Braking System (ABS) / 14

Four-wheel Disc Brakes / 14

Four-wheel Independent Suspension / 9

Fuel Pump Inertia Shutoff Switch / 14

Gauges / 10, 11, 18

Green Zone / 10, 11, 18

Groups/Packages / 13, 14

Leather Comfort Group

Appearance Package

Premium Package

Safety Package

Illuminated Entry System / 14

Instrument Panel Cluster / 11, 18

Intelligent 4WD System / 9

Interior Volume / 11

Lower Anchors and Tethers for Children (LATCH) / 14

Maintenance Requirements / 15

Maximizing Fuel Economy / 10

Message Center / 11

Moonroof / 12

Nickel-metal Hydride (Ni-MH) Battery Pack / 6, 8

110-volt Power Point Outlet / 12

Perimeter Alarm / 14

Personal Safety System® / 14

Powertrain Features / 6

Rear-door Child Safety Locks / 14

Regenerative Braking System / 6, 8

Safety Belts / 14

Seating / 11, 12, 13, 14, 17

SecuriLock® Passive Anti-theft System / 14

70-kilowatt Electric Traction Motor / 6, 7

60/40 Split Rear Seatbacks / 11, 12

Tilt Steering Wheel with Speed Control / 11

Tire Pressure Monitoring System / 14

2.3L Atkinson Cycle 4-cylinder Gas Engine / 6, 7

Unibody Construction / 13, 14

Vehicle Performance / 6

System Horsepower

Acceleration

Fuel Economy

Range

Vehicle System Controller / 6, 7

Warranty Coverage / 15

Wheels / 13, 17

## WHAT'S NEW

### This page is about:

- Overview
- Exterior Changes
- Unique Hybrid Features
- Key Competitors

# 2007 Escape Hybrid

## What's New

### Overview

#### ESCAPE HYBRID



- It was the first hybrid SUV and the first American-made hybrid
- Escape Hybrid is a no-compromise SUV that has all the advantages of a full hybrid system AND all the benefits of a Ford Escape

### Exterior Changes

- Colors added:
  - Vista Blue Clearcoat Metallic (G9)
  - Dune Pearl Clearcoat Metallic (ND)
  - Tungsten Grey Clearcoat Metallic (T8)
- Colors deleted:
  - Dark Shadow Grey Clearcoat Metallic (CX)
  - Sonic Blue Clearcoat Metallic (SN)

## Unique Hybrid Features

- Hybrid features not found on base Escape:
  - Unique instrument panel cluster
  - Unique Hybrid badging (HYBRID with Road & Leaf)
  - Electric Power Assist Steering (EPAS)
  - Standard power four-wheel disc brakes
  - Unique 16-inch aluminum wheels and mini aluminum spare
  - Outside air vent located at the driver's-side rear window (for battery temperature control)
- Hybrid System consists of:
  - Vehicle System Controller (VSC)
  - 2.3L Atkinson cycle 4-cylinder engine
  - 330-volt nickel-metal hydride (Ni-MH) battery pack (weighs approximately 200 lbs.)
  - Electronically Controlled Continuously Variable Transmission (eCVT)
  - 70-kilowatt electric traction motor
  - Electric generator motor
  - Regenerative braking system
- Escape features not available on Escape Hybrid:
  - Cargo floor hooks
  - Step bars
  - Trailer-Tow Package
  - Cargo Convenience Group
- Many states offer hybrid purchasers additional benefits. For details specific to your area:
  - Call the Hybrid Incentive Hotline at 1-866-247-7187
  - Learn more at [irs.gov](http://irs.gov)

### Key Competitors

Escape Hybrid was the world's first production full hybrid SUV but there are several other hybrid vehicles available for sale or about to enter the market. These vehicles include:

- Toyota products (full hybrid)
- Lexus products (full hybrid)
- Honda products (mild hybrid)
- GM products (mild hybrid)

All of these vehicles tend to market themselves as fuel-efficient and environmentally conscious alternatives to conventional gasoline-powered vehicles.

# 2007 Escape Hybrid

## What's Important

### WHAT'S IMPORTANT

This page is about:

Product Highlights

Key Features

## Product Highlights

HERE ARE THE **MOST IMPORTANT** 2007 ESCAPE HYBRID FEATURES TO MENTION TO YOUR CUSTOMERS:

**330-volt nickel-metal hydride (Ni-MH) battery pack** (pgs. 6, 8)

**Safety Package with Safety Canopy™ System and dual front side airbags** (pg. 14)

**Intelligent 4WD System** (pg. 9)

**5-passenger seating with outstanding cargo flexibility** (pgs. 11, 12)

**Outstanding fuel economy while providing V-6-like acceleration** (pgs. 6, 10)

**Electric generator motor** (pgs. 6, 7)

**Regenerative braking system** (pgs. 6, 8)



## Key Features

### Performance/Handling

- 330-volt nickel-metal hydride (Ni-MH) battery pack
- 2.3L Atkinson cycle 4-cylinder gas engine
- Electronically Controlled Continuously Variable Transmission (eCVT)
- 70-kilowatt electric traction motor
- Electric generator motor
- Regenerative braking system
- Front-wheel drive
- Intelligent 4WD System
- Four-wheel independent suspension
- Outstanding fuel economy while providing V-6-like acceleration
- Extended range — 400–500 miles between fill-ups in city driving
- California SULEV II and ATPZEV standards and Tier 2 Bin 3 federal standard (meets some of the strictest emissions requirements to date)
- No special fuel or plug-ins
- Electric power-assisted steering (EPAS)

### Comfort/Convenience

- 60/40 split rear seat with fold-flat feature
- 5-passenger seating with outstanding cargo flexibility
- Automatic transmission floor gearshift
- Flow-through floor console with large, deep cup holders, front storage bin, one power point
- Hybrid Energy/Navigation/Audio System
- AM/FM stereo with 6-disc in-dash CD player. Includes MP3 readable and satellite ready radio capable
- Similar cargo space and passenger room, compared to conventional Escape

- Message center
- 6-way power driver's seat
- Tilt steering with steering-wheel-mounted speed control
- 110-volt power point outlet

### Design/Styling

- Classic "Ford Tough" SUV styling
- Unibody construction
- Rear liftgate with flip-up glass
- Unique 16-inch wheels and tires
- Appearance Package
- Premium Package
- Hybrid badging

### Safety/Security

- Four-wheel Anti-lock Braking System (ABS)
- Personal Safety System® with dual-stage driver and single-stage front passenger airbags with Front Passenger Sensing System (FPSS) for front passenger seat airbag
- Safety Package with Safety Canopy™ System and dual front side airbags
- SecuriLock® passive anti-theft system
- LATCH System
- Belt-Minder® system
- 3-point safety belts and adjustable head restraints in all 5 seating positions

### Quality/Reliability/Durability

- New Vehicle Limited Warranty and Ford Roadside Assistance Program
- 10,000-mile oil changes
- Extended Hybrid warranty (includes battery pack)

NOTE: Feature/product availability: Latest Dealer Ordering Guide.

March 2006

## MODEL LINEUP

This page is about:

- Standard Equipment
- Optional Equipment

# 2007 Escape Hybrid

## Model Lineup

### Standard Equipment

#### Performance/Handling

- 15.0 gallon fuel tank
- 4-wheel independent suspension
- Anti-lock Braking System (ABS)
- Drivetrain
  - FWD (front-wheel drive)
  - 4WD – (four-wheel drive) Intelligent 4WD system
- Electric Power Assisted Steering (EPAS)
- Escape Hybrid Powertrain System
  - 2.3L 4V I-4 Atkinson Cycle Engine
  - Permanent Magnet electric motor
  - Regenerative Braking System
  - 330V Sealed Nickel-Metal Hydride (Ni-MH) battery
  - Electronically Controlled Continuously Variable Transmission (eCVT)
- Power 4-wheel disc brakes
- P235/70R16 A/S BSW tires

#### Comfort/Convenience

- Accessory delay for power windows
- Air conditioning, manual
- AM/FM 6-Disc in-dash CD player, MP3 readable and satellite ready radio capable
- Assist handles – 1st row (2)
- Assist handles – w/coat hooks, 2nd row (2) (NA w/optional Safety Package 85S)
- Center dome lamp w/map lights
- Center horn pad on steering wheel

- Floor mats – color-keyed carpeted front floor mats w/driver retention hook
- Floor shift & console – 2 cupholders & storage bin
- Front seats – low-back bucket seats with adjustable head restraints, premium cloth, driver and passenger map pockets
- Interior lights off delay
- Locking glove box
- Message center
- Power 6-way driver seat
- Power-adjustable sideview mirrors with manual fold feature — molded-in-color, black
- Power door locks
- Power point (1) with cap, in center console
- Power windows with one-touch-down driver's side feature
- Rear cargo area light
- Rear floor heat ducts
- Rear seat – 60/40 split seat, premium cloth, with tip-fold-flat latch, and adjustable head restraints
- Rearview Mirror (Day/Night)
- Removable rear seat cushion
- Steering-wheel-mounted speed control
- Solar tinted glass (on door glass & liftgate)
- Tilt steering wheel

- Visors, Driver & passenger, cloth-covered, with vanity mirror
- Wipers & washers – front variable intermittent/low/high and rear 2 speed

#### Design/Styling

- All clearcoat paint
- Black surround grille with black mesh center
- Body cladding & rocker moldings – Molded-in-color, Grey
- Bumpers 2 1/2 mph, front & rear – Molded-in-color, Grey
- Center finish surround – painted (warm steel) center finish & front door switch bezels
- Clear lens headlamps, 3-color taillamps, center high mount brake light
- Dot matrix windshield pattern
- Exterior door handle – full grip ergonomic – Molded-in-color, Black
- Front fog lamps
- Hybrid-unique 16" aluminum wheels
- Liftgate molding – Black
- Privacy glass – rear doors, rear quarter windows and rear liftgate flip-up glass
- Rear window defroster
- Roof side rails, black
- Wheelbase (103.2")
- White-faced instrument cluster – instrument panel warning signals & unique hybrid gauges

#### Safety/Security

- Airbags – dual stage front driver and single stage front passenger with Front Passenger Sensor System
- Battery saver w/headlamp off delay
- Belt-Minder®
- Child safety locks (rear doors)
- Driver and front passenger seats – Safety belt pretensioners & height adjustable D-rings
- Illuminated entry
- LATCH system (Lower Anchors & Tethers for CHildren) on rear outboard seat locations
- Mini-size spare wheel & tire (underbody mounted)
- Perimeter alarm
- Remote keyless entry w/2 key fobs
- Safety belt restraint system – manual 3-point shoulder & lap safety belt system, and headrests on all seating positions
- Securilock® passive anti-theft system
- Side intrusion door beams
- Tire Pressure Monitoring System (TPMS)
- Wheel nut wrench & jack

#### Quality/Reliability/Durability

- Unibody construction

**NOTE:** The above information is an excerpt from page 3 of the 3/13/06 Escape Hybrid Dealer Ordering Guide. Latest Dealer Ordering Guide: [fmcdealer.com](http://fmcdealer.com)

### Optional Equipment

	Hybrid
<b>Comfort/Convenience</b>	
AC 110V Power Outlet, Front console	O
Floor mats, Rear	O
Hybrid Energy Audio & Navigation System	O
Leather Comfort Group (NA w/Premium Package)	O
License Plate Bracket, Front	O
Moonroof (Available only when Premium Package is ordered)	O
Premium Package (NA w/Appearance Package)	O
Seats:	
Front & Rear Leather-trimmed Seats w/Map Pockets (driver & passenger), 6-Way Power Driver Seat	P
<b>Design/Styling</b>	
Appearance Package (NA w/Premium Package)	O
<b>Safety/Security</b>	
Safety Package	O

S = Standard    O = Optional    P = Packaged Option

**NOTE:** The above information is an excerpt from page 5 of the 3/13/06 Escape Hybrid Dealer Ordering Guide. Restriction information and the Latest Dealer Ordering Guide: [fmcdealer.com](http://fmcdealer.com)























## AUDIO

### This page is about:

- Premium AM/FM Stereo/6-disc In-dash CD Player
- Hybrid Energy/Navigation/Audio System
- SIRIUS Satellite Radio

# 2007 Escape Hybrid

## Audio

### Premium AM/FM Stereo/6-disc In-dash CD Player

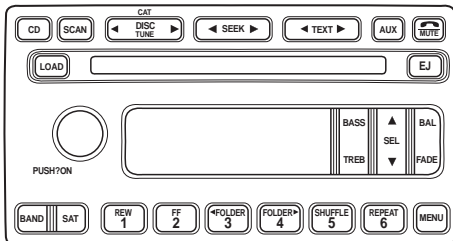

- 80 watts
- 4 speakers
- RDS (Radio Data System) function
- Random shuffle across all CDs
- Selective eject/load capability
- MP3 readable and satellite ready radio capable

### Hybrid Energy/Navigation/Audio System



*Includes or replaces features of premium AM/FM stereo/6-disc in-dash CD player plus:*

- 3.8-inch display screen
- Navigation capability with full map and turn-by-turn voice directions
- Fuel economy display
- Hybrid energy flow graphic
- Single-disc CD player
- AM/FM Audiophile radio with 4 speakers and 6-disc CD changer located under front passenger seat
- MP3 readable and satellite ready radio capable

### SIRIUS Satellite Radio

- SIRIUS satellite radio-ready with Satellite button (SAT) to activate the system, Text button (TEXT) to provide information about the artist and song title, and Category button (CAT) to scroll through a variety of format types
- Key benefits of SIRIUS Satellite Radio include:
  - 100 percent commercial-free music
  - Seamless coverage anywhere in the continental U.S. (not equipped to operate in Alaska or Hawaii)
  - 120 channels of the best commercial-free music, talk, news and information (65 music channels)
- Requires dealer-installed kit to activate service, which consists of antenna, Down Link Processor (DLP) and wire harness. Once the hardware is in place, the owner can apply for the SIRIUS satellite radio subscription service for a monthly fee
- Installation of the kit can be done through Visteon distribution centers — or dealerships have the option of installing the kits in-house. For more details on installation, please contact Visteon at (800) 367-3333
- More information on the service is available online at [sirius.com](http://sirius.com) or toll-free at (888) 539-SIRIUS (7474)

### For More Audio Information

- Audio availability: Latest Dealer Ordering Guide
- Operating information: Vehicle Owner's Guide

# 2007 Escape Hybrid

## Wheels/Seats

### WHEELS/SEATS

#### This page is about:

- 16" Aluminum Wheel
- Premium Cloth Front Bucket Seats
- Leather-trimmed Front Bucket Seats
- Premium Leather-trimmed Front Bucket Seats

### Wheel



16" Aluminum Wheel  
(Unique for Escape Hybrid)

### Seats

	Interior Colors
<b>Interior Trim Type and Color Selector</b> NOTE: First character denotes type, second character denotes color.	Medium/Dark Flint
Premium Cloth Front Bucket Seats with 60/40 Split Rear Seat	A2
Leather-trimmed Front Bucket Seats with 60/40 Split Rear Seat	N2
Premium Leather-trimmed Front Bucket Seats with 60/40 Split Rear Seat (Available only with Premium Package)	C2

NOTE: Illustrations of the available seating choices: 2007 Color and Upholstery Book or the Specifications section of eSourceBook ([esourcebook.dealerconnection.com](http://esourcebook.dealerconnection.com)).

This page is about:

- Instrument Cluster
- Maximum Allowable Weight
- Cargo/Payload GVWR Worksheet

### Instrument Cluster

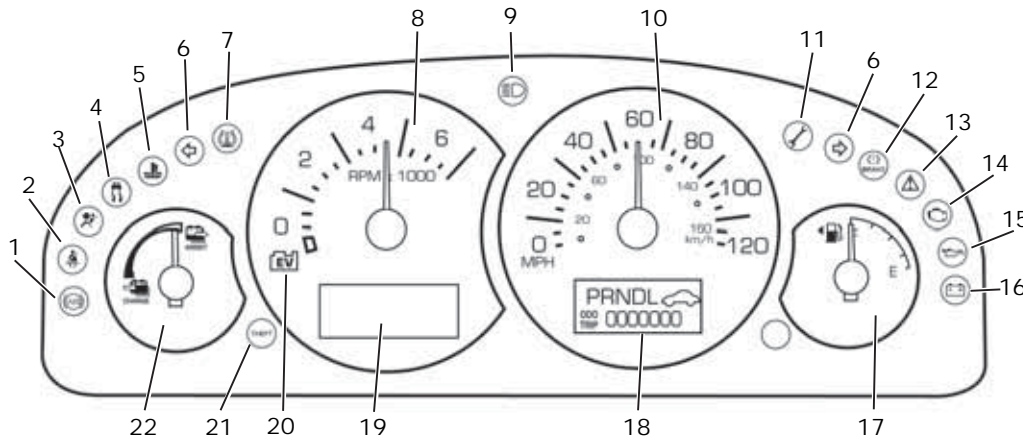

- |   |  |   |
|---|--|---|
| <ol style="list-style-type: none"> <li>1. Anti-lock Braking System (ABS) indicator/warning light</li> <li>2. Fasten safety belt indicator/warning light</li> <li>3. Airbag readiness indicator/warning light</li> <li>4. ABS active indicator</li> <li>5. Engine coolant temperature warning light</li> <li>6. Turn signal indicator</li> </ol> | <ol style="list-style-type: none"> <li>7. Tire pressure monitor system indicator/warning light</li> <li>8. Tachometer</li> <li>9. High-beam indicator</li> <li>10. Speedometer</li> <li>11. Service soon warning light</li> <li>12. Brake system warning light/parking brake on indicator</li> <li>13. Master vehicle electrical hazard warning light</li> <li>14. Check engine warning light</li> </ol> | <ol style="list-style-type: none"> <li>15. Oil pressure warning light</li> <li>16. Underhood battery voltage indicator</li> <li>17. Fuel gauge</li> <li>18. Transmission gearshift indicator/odometer/speedometer</li> <li>19. Message Center display</li> <li>20. "Green zone" electric-only mode indicator</li> <li>21. Passive anti-theft indicator light</li> <li>22. Battery pack state gauge</li> </ol> |
|---|--|---|

### Maximum Allowable Weight (lbs.) (Regular Production Options and Aftermarket Equipment)

Model	GVWR (lbs.)	Engine — 2.3L/eCVT
FWD	4680	166
4WD	4760	131

NOTE: Above weights assume 750 lbs. driver and passengers' allowance and 150 lbs. of cargo.

### Total Actual Regular Production Option Content Weight Cargo/Payload GVWR Worksheet

Option Weight	(Front/Total) (lbs.)
Reverse Proximity Sensor	(0/2)
Rear Floor Mats	(0/2)
Cargo Area Retractable Cover	(-1/7)
Immersion Heater — Engine	(1/1)
Mini-overhead Console	(5/5)
Navigation System	(5/5)
Moonroof	(13/36)
7-speaker System	(0/14)
Electrical Outlet	(2/2)
Heated Mirrors	(1/1)
Air Curtain Restraints	(4/9)
Side Impact Package	(3/6)
Heated Seats — Driver/Front Passenger	(2/6)
Wheellip Moldings	(2/4)
Leather-wrapped Steering Wheel	(1/1)
Leather-trimmed Seats	(2/5)
Subtotal: Front/Total	___ / ___

NOTE: Refer to the Payload Workbook section of the 2007 Appendices book.

## Dimensions

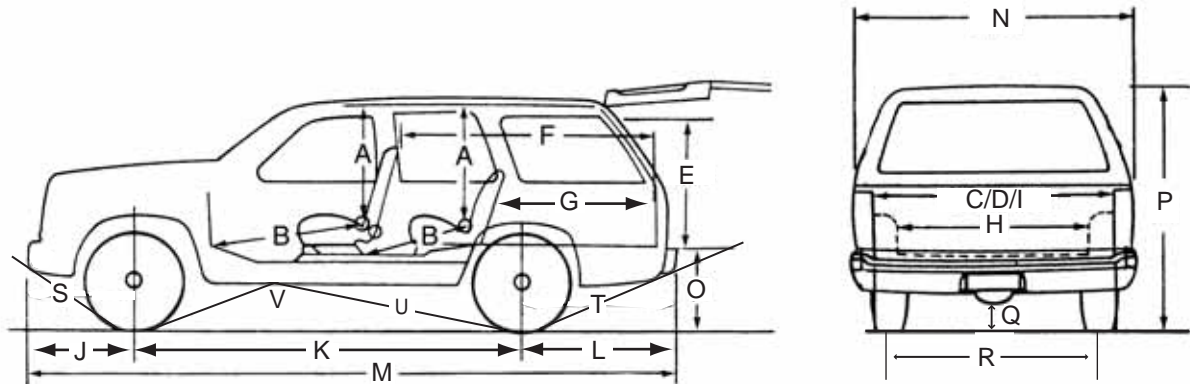

### Escape Hybrid

Code	Description	Inches
A	Head Room (Front Row)	40.4
	Head Room (Second Row)	39.2
B	Leg Room (Front Row)	41.6
	Leg Room (Second Row)	35.6
C	Shoulder Room (Front Row)	56.3
	Shoulder Room (Second Row)	55.9
D	Hip Room (Front Row)	53.2
	Hip Room (Second Row)	49.1
E	Cargo Rear Opening Height	33.0
F	Cargo Length Front (at Belt)	60.3
G	Cargo Length Second (at Belt)	25.5
H	Cargo Width — Wheelhouse	40.8
I	Rear Opening Width @ Floor	43.7
J	Front Overhang	34.0
K	Wheelbase	103.2
L	Rear Overhang	37.7
M	Vehicle Length	174.9
N	Vehicle Width Excluding Mirrors	70.1
O	Cargo Floor Height to Ground <sup>(1)</sup>	30.3
P	Overall Height with Roof Rack <sup>(1)</sup>	69.9
Q	Ground Clearance — Minimum	8.2
R	Front/Rear Track (Empty)	61.1/60.4
S	Approach Angle (Empty)	21.4°
T	Departure Angle (Empty)	28.7°
U	Ramp Breakover Angle (Empty)	21.2°
V	Step Height (Empty)	20.5

(1) The height data shown represents dimensions of a nominal vehicle with no options. Actual height may vary due to production tolerances.

# 2007 Escape Hybrid

## *Dimensions cont'd*

### FUEL TANK CAPACITY

Engine	Availability	Location	Capacity (gallons/liters)
All	Standard Tank (Steel)	Midship	15g/57L

### CARGO VOLUME

Escape Hybrid	Cu. Ft.
Behind First Row (Second-Row Cushion Removed)	65.5
Behind First Row (Second-Row Cushion Up)	62.1
Behind Second Row	27.6

### BASE CURB WEIGHTS

Escape Hybrid Model	Engine	GVWR (lbs.)	Front (lbs.)	Rear (lbs.)	Total (lbs.)
FWD	2.3L I-4/eCVT	4680	2075	1535	3610
4WD	2.3L I-4/eCVT	4760	2152	1623	3775

# 2007 Escape Hybrid

## Seating Capacity and Standard Equipment Specifications

ESCAPE HYBRID

### ESCAPE Hybrid (103.2" WB)

<b>DRIVE:</b>		Front-Wheel Drive	Four-Wheel Drive
<b>GVWR: (lbs.)</b>	— Computer Selected (Not Published in Advertising)	4680	4760
<b>PASSENGER CAPACITY</b>		5	5
<b>SEATING ARRANGEMENTS INCLUDE:</b>			
	Low-Back Bucket Seats	■	■
	60/40 Split Bench Seat (3-Pass.)	■	■
<b>PASSENGER CAPACITY (lbs.)</b>		750	750
<b>CARGO CAPACITY (Max.) (lbs.)</b>		245	260
<b>GAWR (lbs.):</b>			
	Front — Min./Max.	2440	2440
	Rear — Min./Max.	2400	2400
<b>POWERTRAIN:</b>			
	Engine — Application	Refer to Dealer Ordering Guide for 50 States Usage	
	— Type (Min.)	2.3L I-4 Atkinson Cycle	
	Transmission — Type (Min.)	Electronically Controlled Continuously Variable Transmission (eCVT)	
	Intelligent 4WD System — Type	—	Intelligent 4WD System
	— 4WD Mode	—	4x4 AUTO—Splits Torque on Demand
	— Front/Rear Torque Proportioning Device	—	Power Transfer Unit Mounted to Transmission Transfers Power to the Rear Axle Through 2-piece Driveshaft. Electromagnetic Coupling Located Between End of the Driveshaft and Rear Axle Differential Governs Front/Rear Torque Split
<b>BRAKES:</b>			
	Front Disc — Type	Power-assisted, Ventilated 4-wheel Disc with Standard ABS and Integrated Regenerative Braking	
	— Size	10.93" Diameter	
	Rear Disc — Type	Power-assisted, Ventilated 4-wheel Disc with Standard ABS and Integrated Regenerative Braking	
	— Size	11.89" Diameter	
	Power-assist Unit — Type	Dual-Diaphragm	
	— Effective Dia.	8.00/9.00"	
	Anti-lock System	4-Channel, 4-Wheel ABS with Electronic Brake Force Distribution	
	Parking Brake (Rear Brakes)	Lever-type, Hand-operated, Hand Release	
<b>ELECTRICAL:</b>			
	Motor	Permanent Magnet AC Synchronous	
	Battery — Type	Maintenance-free (Battery Saver System Standard)	
	— Rating	52 Amp-hr., 550 CCA	
	Ni-MH Battery — Rating	330V	
	— Type	Sealed Nickel-metal Hydride	
<b>FRAME:</b>			
	— Type	Unitized Body Structure	
<b>FUEL TANK, MIDSHIP:</b>	— Capacity	15 Gal. (57L)	

# 2007 Escape Hybrid

## Seating Capacity and Standard Equipment Specifications cont'd

### ESCAPE Hybrid (103.2" WB) cont'd

<b>DRIVE:</b>		Front-Wheel Drive	Four-Wheel Drive
<b>GVWR: (lbs.)</b>	— Computer Selected (Not Published In Advertising)	4680	4760
<b>STEERING:</b>	— Type	Rack-and-Pinion with Electric Power Assist	
	— Ratio	17.9:1	17.9:1
<b>SUSPENSION:</b>			
Suspension, Front	— Type	Independent, MacPherson Struts, Lower Control Arms, Coil Springs and Stabilizer Bar	
	— Spring Rating (lbs.)	2440	2440
	— Stabilizer Bar	Standard	
Suspension, Rear	— Type	Multi-link Suspension with Lateral Links, Trailing Arms, Shock Absorbers and Coil Springs	
	— Spring Rating (lbs.)	2400	2400
<b>TIRES:</b>	— No./Type	Four, Steel-belted Radial, All-season	
	— Size	P235/70R16 BSW	
	— Spare Tire	T155/80D18 Temporary Mini-Spare (Stowed Under Rear of Vehicle on Winch System)	
<b>WHEELS:</b>	— No./Type	Four, 5-hole Disc, 5-spoke	
	— Type	Aluminum	
	— Size	16" x 7"	
	— Spare Wheel	Aluminum, 18" x 4.0" Temporary Mini-Spare (Stowed Under Rear of Vehicle on Winch System)	

### TIRE/WHEEL AVAILABILITY

<b>WHEELS</b>	16" x 7" Aluminum
<b>TIRES</b>	P235/70R16 A/S BSW <sup>(1)</sup>

(1) Includes temporary T155/80D18 spare tire on 18"x 4" Mini-Spare wheel.

NOTE: Set of four tires and wheels with four center caps and Temporary Mini-Spare. Spare tire and wheel stored under rear of vehicle on winch system.

### ENGINE/TRANSMISSION/AXLE COMBINATIONS

Engine	Transmission	Axle Ratio
2.3L 4 Valve I-4 Atkinson Cycle	eCVT	50 States 2.93
		Std.

NOTE: Brake/shift interlock included with automatic transmission. An auxiliary oil cooler is standard with the 4-speed automatic overdrive transmission.

## Technical Specifications

### Brakes

#### HYDRAULIC BRAKE EQUIPMENT SPECIFICATIONS — FRONT DISC

Type	Rotor Dia. (in.)		Brake Lining Segment	Area (sq. in.)/ Width (in.)/ Thickness (in.)	Caliper Piston Dia. (in.)	Gross Lining Area Per Axle (sq. in.)	Total Swept Area Per Axle (sq. in.)
	OD	ID					
Disc	10.93	6.73	Outboard	8.1/4.09/.35	Single 2.60	32.40	248.16
			Inboard				

#### HYDRAULIC BRAKE EQUIPMENT SPECIFICATIONS — REAR DISC

Type	Rotor (in.)			Park Brake Hat (in.)		Brake Lining Segment	Area (sq. in.)/ Width (in.)/ Thickness (in.)	Caliper Piston Dia. (in.)	Gross Lining Area Per Axle (sq. in.)	Total Swept Area Per Axle (sq. in.)
	OD	ID	Thickness	Dia.	Width					
Disc	11.89	8.19	0.47	7.28	1.18	Outboard	4.74/4.33/0.47	Single 1.57	18.97	218.53
						Inboard				

#### BRAKE MASTER CYLINDER SPECIFICATIONS

Type	Bore Dia. (in.)
Dual System, Dash Mounted	1.0625

#### POWER BRAKES VACUUM BOOSTER SPECIFICATIONS

Make/Type	Effective Dia. (in.)	Diaphragm Type
Dash Mounted	8.00/9.00	Dual

### Cooling Systems

#### COOLING SYSTEM SPECIFICATIONS

Engine	Cooling	Trans. Usage (sq. in.)	Frontal Area (sq. in.)	Core Size (in.)			Rows of Tubes	Fins Per Inch	Cooling System Capacity (approx. qts.)	Fan Specifications	
				Height	Width	Thick.				Number/Watts	Blade Dia. (in.) <sup>(1)</sup>
2.3L I-4	Std.	Auto.	506	18.38	27.56	1.02	41	85	—	Dual 80 Watt	12.59

(1) 5-blade fan on L.H. side and 6-blade fan on R.H. side.

### Fuel System

#### FUEL SYSTEM DATA

Electronic Fuel Injection	2.3L 4V I-4 Atkinson Cycle	Sequential Multiport Fuel Injection
---------------------------	----------------------------	-------------------------------------

### Steering

#### STEERING SPECIFICATIONS

Engine	Tire Size	Power Steering	Turning Diameter (ft.)	
		Gear Ratio	Curb-to-Curb	Wall-to-Wall
2.3L I-4	P235/70R16	17.9:1	37.7	40.1
	T155/80D18	17.9:1	37.7	40.1

# 2007 Escape Hybrid

## Technical Specifications cont'd

### Suspensions

#### SUSPENSION, FRONT

Model	Front-Wheel Drive	Four-Wheel Drive
Type	Independent, MacPherson Struts Attached to L-shaped Lower Control Arms (Dual Path Upper Strut Mount with Strut and Coil Spring Mounted Separately) and Front Stabilizer Bar	
Capacity (lbs.)	2440	2440

#### SUSPENSION, REAR

Model	Front-Wheel Drive	Four-Wheel Drive
Type	Independent, Double Lateral Link and Semi-Trailing Arms (Coil Springs Located Between Trailing Arms and Body)	
Capacity (lbs.)	2400	2400

### Tires and Wheels

#### TIRE SPECIFICATIONS

Size	Rim Width (in.)	Section Width (in.)	Load/Ply Rating	Maximum Inflation Pressure (psi)	Load Limits @ Maximum Inflation Pressure (lbs.)	Static Loaded Radius (in.)	Revolutions Per Mile @ 45 mph
P235/70R16 All-Season BSW (T-Rated)	7.0	9.09	Std.	44	1984	13.30	728
T155/80D18 Mini Spare	5.0	7.6	Std.	60	1874	11.8	793

#### WHEEL SPECIFICATIONS

Wheel Type	Wheel Size	Inset (in.)	No. of Studs	Bolt Circle (in.)	Max. Wheel Capacity Load (lbs. @ ground)
Aluminum	16" x 7.0" J	1.77	5	4.49	1240
Aluminum Mini Spare	18" x 4.0" T	1.77	5	4.49	1240

### Transmission

#### AUTOMATIC TRANSMISSION

Make/Type	Hybrid Electric PowerSmart Automatic Transmission Electronically Controlled Continuously Variable Transmission (eCVT)
-----------	---